

FEATURES

- Forged brass manifold with exclusive lifetime warranty
- New, over-sized connecting rods for ultimate crankcase performance
- Die cast, anodized aluminum, oil-bath crankcase
- Solid ceramic plungers with continuously lubricated packings
- The original Interpump unitized, stainless steel, K123 inlet and outlet valves
- Ideal for all general cleaning applications
- Comes standard with either SAE J609 gasoline engine mounting flange, or NEMA 56C mounting flange.*
- Also available in "L" left-handed versions



SPECIFICATIONS

| Pump Model | TP2520J34UIL | TP2526J34UIL | TP2530J34UIL | TP2533J34UIL |
|--------------------------------|--------------------------|--------------|--------------|--------------|
| Maximum Volume | 1.9 GPM | 2.6 GPM | 2.88 GPM | 3.3 GPM |
| Maximum Discharge Pressure | 2500 PSI | | | |
| Rated Pump Speed | 3400 RPM | | | |
| Maximum Inlet Pressure | 125 PSI | | | |
| Maximum Inlet Vacuum | 3 ft. water (2.6 in. Hg) | | | |
| Bore | .591 in. / 15 mm | | | |
| Stroke (in. / mm) | .197 / 5 | .260 / 6.6 | .283 / 7.2 | .315 / 8 |
| Crankcase Oil Capacity | 11.0 oz. | | | |
| Maximum Fluid Temperature | 165°F | | | |
| Pump Inlet Port Thread | 3/8-19 BSPP-F | | | |
| Unloader Inlet Port Thread | 1/2-14 BSPP-F** | | | |
| Pump Discharge Port Thread | 1/4-19 BSPP-F | | | |
| Unloader Discharge Port Thread | 3/8-19 BSPP-M | | | |
| Hollow Shaft I.D. | 3/4 in. / 19 mm | | | |
| Weight | 11.4 lbs. | | | |
| Dimensions | 7.0 x 7.2 x 5.5 in. | | | |

****DO NOT use NPT Inlet Fitting; GP 680006 Inlet Fitting is recommended.**

DIMENSIONAL DRAWING

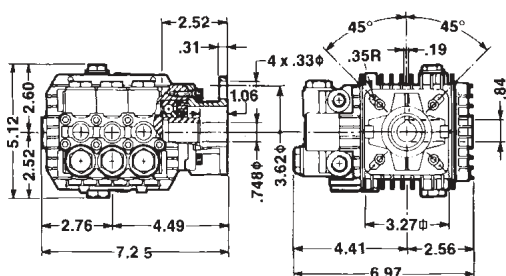

J34 Version

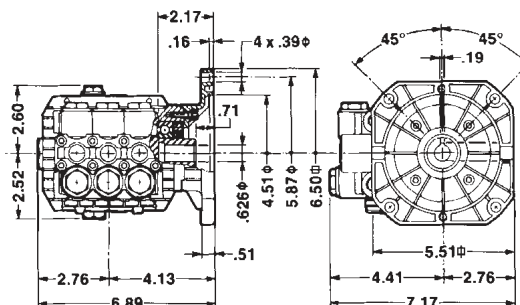

X34 Version

NOTE:
Overall height w/unloader=8"



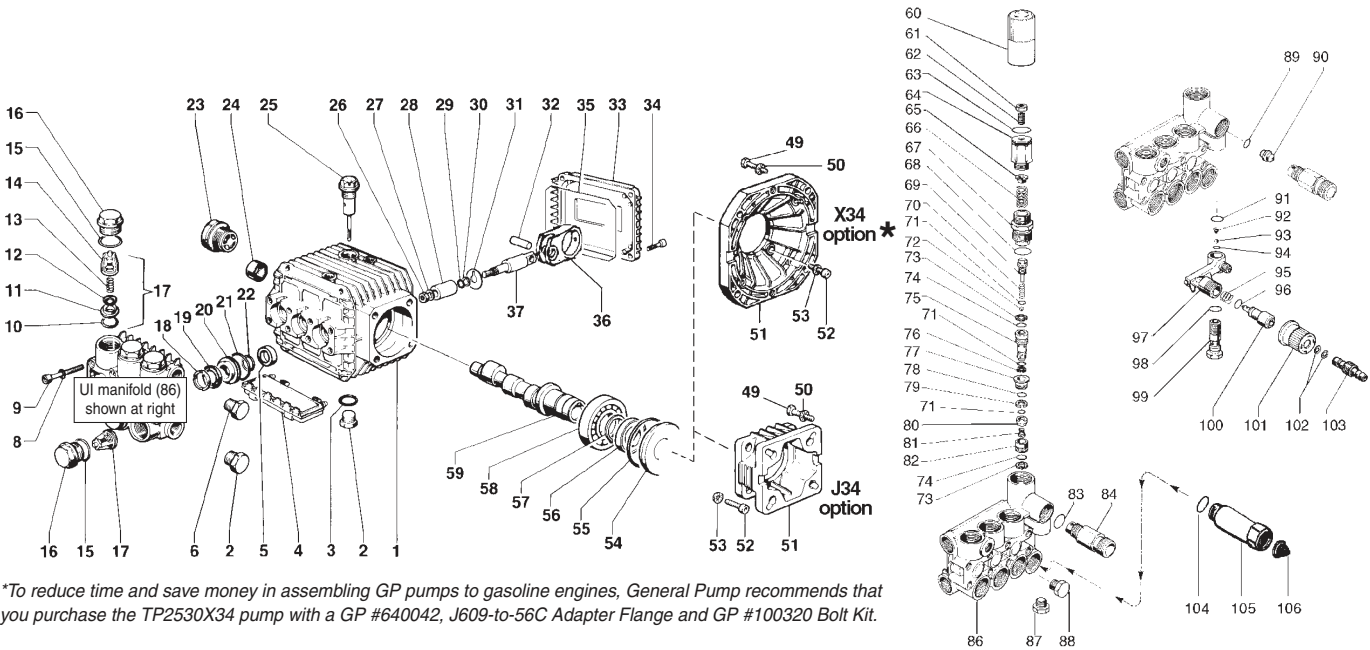

*To reduce time and save money in assembling GP pumps to gasoline engines, General Pump recommends that you purchase the TP2530X34 pump with a GP #640042, J609-to-56C Adapter Flange and GP #100320 Bolt Kit.

PARTS LIST

| ITEM | PART NO. | DESCRIPTION | KIT NO. | QTY. | ITEM | PART NO. | DESCRIPTION | KIT NO. | QTY. | ITEM | PART NO. | DESCRIPTION | KIT NO. | QTY. |
|------|------------|------------------|----------|------|------|------------|--------------------|---------|------|-----------------|-----------------------|--------------------|----------|------|
| 1. | 51.0106.22 | Crankcase | | 1 | 37. | 51.0500.56 | Plunger Rod | | 3 | 77. | 36.3165.70 | Valve Guide | 102 | 1 |
| 2. | 98.2100.00 | Plug, 3/8 | | 1 | 49. | 99.2730.00 | Screw, J34 | | 4 | 78. | 90.3589.00 | O-Ring | 102 | 1 |
| 3. | 90.3833.00 | O-Ring | | 1 | 99. | 93345.00 | Screw, X34 | | 1 | 79. | 90.5075.00 | Back-up Ring | 102 | 1 |
| 4. | 51.2091.02 | Protector | | 1 | 50. | 96.7014.00 | Washer, J34 | | 4 | 80. | 36.3190.66 | Valve | 102 | 1 |
| 5. | 90.1565.00 | Oil Seal | 83 | 3 | 51. | 96.7104.00 | Washer, X34 | | 1 | 81. | 99.1509.00 | Screw | 102 | 1 |
| 6. | 98.2041.00 | Plug, 1/4 | | 1 | 51. | 10.0346.22 | Flange, J34 | | 1 | 82. | 36.3164.66 | Valve Seat | 102 | 1 |
| 8. | 96.6938.00 | Washer | | 8 | | 10.0344.22 | Flange, X34 | | 1 | 83. | 90.3832.00 | O-Ring | 94 | 1 |
| 9. | 99.1943.00 | Screw | | 8 | 52. | 99.1867.00 | Screw | | 4 | 84. | 10.0078.70 | Nipple, 3/8 BSPP-M | | 1 |
| 10. | 90.3841.00 | O-Ring | 123 | 6 | 53. | 96.6938.00 | Washer | | 4 | | 10.0147.70 | Nipple, M22-M | optional | |
| 11. | 36.2003.66 | Valve Seat | 123 | 6 | 54. | 50.2115.51 | Spacer | | 1 | | 10.0318.70 | Nipple, 3/8 NPT-F | optional | |
| 12. | 36.2001.76 | Valve Plate | 123 | 6 | 55. | 90.4097.00 | O-Ring | | 1 | 86. | 51.1201.41 | UI Manifold | | 1 |
| 13. | 94.7376.00 | Spring | 123 | 6 | 56. | 90.1644.00 | Oil Seal | | 1 | 87. | 98.2057.00 | Cap | | 1 |
| 14. | 36.2025.51 | Valve Cage | 123 | 6 | 57. | 90.0667.00 | Snap Ring | | 1 | 88. | 98.2041.00 | Cap | | 1 |
| 15. | 90.3847.00 | O-Ring | | 6 | 58. | 20.2835.21 | Bearing | | 1 | 89. | 90.3822.00 | O-Ring | 94 | 1 |
| 16. | 98.2216.00 | Valve Cap | | 6 | 59. | 51.0210.65 | Crankshaft, TP2520 | | 1 | 90. | 10.0151.66 | 2 mm Nozzle | | 1 |
| 17. | 36.7115.01 | Valve Assy. | 123 | 6 | | 51.0211.65 | Crankshaft, TP2526 | | 1 | 91. | 90.3582.00 | O-Ring | 94 | 1 |
| 18. | 51.1000.51 | Head Ring | 96,97 | 3 | | 51.0221.65 | Crankshaft, TP2530 | | 1 | 92. | 94.8217.00 | Spring | 94 | 1 |
| 19. | 90.2620.00 | Packing | 96,97 | 3 | | 51.0218.65 | Crankshaft, TP2533 | | 1 | 93. | 97.4782.00 | Ball | 94 | 1 |
| 20. | 51.0800.70 | Packing Retainer | 86,96 | 3 | 60. | 36.3187.51 | Knob | | 1 | 94. | 90.3572.00 | O-Ring | 94 | 1 |
| 21. | 90.3604.00 | O-Ring | 86,96,97 | 3 | 61. | 99.3068.00 | Bolt, M8 x 25 | | 1 | 95. | 94.7383.00 | Spring | 94 | 1 |
| 22. | 90.3835.00 | O-Ring | 86,96,97 | 3 | 62. | 92.2223.00 | Nut, M8 | | 1 | 96. | 90.3580.00 | O-Ring | 94 | 1 |
| 23. | 97.5968.00 | Sight Gauge | | 1 | 63. | 90.3598.00 | O-Ring, 20.35x1.78 | | 1 | 97. | 36.3181.51 | Body | | 1 |
| 24. | 20.2128.35 | Needle Bearing | | 1 | 64. | 36.3185.70 | Pressure Regulator | | 1 | 98. | 90.3585.00 | O-Ring | 94 | 1 |
| 25. | 98.2103.00 | Oil Dip Stick | | 1 | 65. | 36.3169.70 | Seat | | 1 | 99. | 36.2563.70 | Valve Seat | | 1 |
| 26. | 92.2216.00 | Nut | | 3 | 66. | 94.7436.00 | Spring, 15 x 36 | | 1 | 100. | 36.2564.70 | Shuttle | | 1 |
| 27. | 96.7008.00 | Washer | | 3 | 67. | 36.3184.70 | Bushing | 102 | 1 | 101. | 36.2565.51 | Knob | | 1 |
| 28. | 51.0400.09 | Plunger (15 mm) | | 3 | 68. | 90.3847.00 | O-Ring | 102 | 1 | 102. | 90.3570.00 | O-Ring | 94 | 2 |
| 29. | 90.3572.00 | O-Ring | | 3 | 69. | 36.3188.70 | Stopper | 102 | 1 | 103. | 36.2566.70 | Coupling | | 1 |
| 30. | 90.5022.00 | Back Up Ring | | 3 | 70. | 94.7332.00 | Spring | 102 | 1 | OPTIONAL | | | | |
| 31. | 96.7070.00 | Finger Washer | | 3 | 71. | 90.3575.00 | O-Ring | 102 | 3 | 104. | 701115 | O-Ring | | 1 |
| 32. | 97.7310.00 | Conn. Rod Pin | | 3 | 72. | 97.4800.00 | Ball | 102 | 1 | 105. | 680006 | Fitting | | 1 |
| 33. | 51.1600.22 | Crankcase Cover | | 1 | 73. | 90.5065.00 | Back-up Ring | 102 | 2 | 106. | 700004 | Filter | | 1 |
| 34. | 99.1867.00 | Screw | | 4 | 74. | 90.3822.00 | O-Ring | 102 | 2 | ZOFILKIT | Chem. Tube & Strainer | | | |
| 35. | 90.3917.00 | Cover O-Ring | | 1 | 75. | 36.3189.70 | Piston | 102 | 1 | | | | | |
| 36. | 51.0301.22 | Connecting Rod | | 3 | 76. | 90.5025.00 | Back-up Ring | 102 | 1 | | | | | |

REPAIR KITS

| KIT NO. | 83 | 86 | 94 | 96 | 97 | 102 | 123 |
|--------------------------------------|----|------------|---|--------------------|----------------|--|--------------------------|
| ITEM NO.s INCLUDED IN KIT | 5 | 20, 21, 22 | 83, 89, 91, 92, 93, 94, 95, 96, 98, 102 | 18, 19, 20, 21, 22 | 18, 19, 21, 22 | 67, 68, 69, 70, 71, 72, 73, 74, 75, 76, 77, 78, 79, 80, 81, 82 | 10, 11, 12, 13, 14, (17) |
| NUMBER OF ASSEMBLIES IN KIT | 3 | 3 | — | 1 | 3 | — | 6 |
| NUMBER OF CYLINDERS KIT WILL SERVICE | 3 | 3 | — | 1 | 3 | — | 3 |

TORQUE SPECS*

| Position | Ft.-lbs. |
|----------|----------|
| 2 | 29.4 |
| 6 | 14.7 |
| 9 | 8.8 |
| 16 | 60.0 |
| 23 | 13.2 |
| 26 | 11.0 |
| 34 | 7.3 |
| 49 | 14.7 |
| 52 | 7.3 |

*Decrease torque by 20% if threads are lubricated.

