



5 Frame Plunger Pump

Models

**30,31
34,35**

FEATURES

Superior Design

- Triplex plunger design gives smoother liquid flow.
- Hi-Pressure Seals are completely lubricated and cooled by the liquid being pumped.
- Inlet and discharge valve assemblies interchange for easier maintenance.
- Lubricated Lo-Pressure Seal provides double protection against external leakage.
- Oil bath crankcase assures optimum lubrication.
- Close tolerance concentricity of the ceramic plunger maximizes seal life.
- Optional gearbox pump version or electric motor option.

Quality Materials

- Precision design 304 stainless steel valves and seats are hardened and polished for ultimate seating and extended valve life.
- Forged brass manifold for strength and corrosion resistance.
- Special concentric, high-density, polished, solid ceramic plungers provide a true wear surface extended seal life.
- Specially formulated, CAT PUMP exclusive, Hi-Pressure Seals offer unmatched performance and seal life.
- Die cast aluminum crankcase provides high strength, minimum weight and precision tolerance control.
- Chrome-moly crankshaft gives unmatched strength and surface hardness.
- Oversized crankshaft bearings with greater loading capacity mean longer bearing life.

Easy Maintenance

- Wet-end is easily serviced without entering crankcase, requiring less time and effort.
- Valve assemblies are accessible without disturbing piping, for quick service.
- Preset packings mean no packing gland adjustment is necessary, reducing maintenance costs.

⚠ WARNING

All systems require both a primary pressure regulating device (i.e., regulator, unloader) and a secondary pressure safety relief device (i.e., pop-off valve, safety valve). Failure to install such relief devices could result in personal injury or damage to the pump or to system components. CAT PUMPS does not assume any liability or responsibility for the operation of a customer's high pressure system.

SPECIFICATIONS

	U.S. Measure	Metric Measure
MODEL 30 Direct Drive		
Flow	3.2 GPM	(12.1 L/M)
Pressure Range	100 to 2200 PSI	(7 to 155 BAR)
RPM	1725 RPM	(1725 RPM)
Inlet Pressure Range	Flooded to 60 PSI	(Flooded to 4 BAR)
Stroke	0.315"	(8 mm)
MODEL 31		
Flow	4.0 GPM	(15 L/M)
Pressure Range	100 to 2200 PSI	(7 to 155 BAR)
RPM	950 RPM	(950 RPM)
Inlet Pressure Range	-5 to 60 PSI	(-0.35 to 4 BAR)
Stroke	0.709"	(18 mm)
MODEL 34 Direct Drive or Gearbox		
Flow	4.0 GPM	(15 L/M)
Pressure Range	100 to 1800 PSI	(7 to 125 BAR)
RPM	1725 RPM	(1725 RPM)
Inlet Pressure Range	Flooded to 60 PSI	(Flooded to 4 BAR)
Stroke	0.394"	(10 mm)
MODEL 35 Direct Drive or Gearbox		
Flow	5.0 GPM	(19 L/M)
Pressure Range	100 to 1500 PSI	(7 to 105 BAR)
RPM	1725 RPM	(1725 RPM)
Inlet Pressure Range	Flooded to 60 PSI	(Flooded to 4 BAR)
Stroke	0.472"	(12 mm)

COMMON SPECIFICATIONS

Bore	0.787"	(20 mm)
Crankcase Capacity	18 oz.	(0.55 L)
Maximum Liquid Temperature	160°F	(71°C)
Above 130°F call CAT PUMPS for inlet conditions and elastomer recommendations.		
Inlet Ports (2)	1/2" NPTF	(1/2" NPTF)
Discharge Ports (2)	3/8" NPTF	(3/8" NPTF)
Shaft Diameter	0.787"	(20 mm)
Weight	20.1 lbs.	(9.1 kg)
Dimensions	11.69 x 8.35 x 5.28"	(297 x 212 x 134 mm)

ELECTRIC HORSEPOWER REQUIREMENTS

MODEL	FLOW		PRESSURE				MOTOR PULLEY SIZE	
	U.S. GPM	L/M	PSI 1200	PSI 1500	PSI 2000	PSI 2200	RPM	Pulley O.D.
31	5.0	19.0	4.1	5.1	N/A	N/A	1190	5.5
	4.5	17.0	3.7	4.6	6.2	6.8	1070	5.0
	4.0	15.0	3.3	4.1	5.5	6.0	950	4.4
30	3.2	12.1	2.6	3.3	4.4	4.8	1725	Direct Drive
34	4.0	15.0	3.3	4.1	5.5	N/A	1725	Direct Drive
35	5.0	19.0	4.1	5.1	N/A	N/A	1725	Direct Drive

DETERMINING THE PUMP R.P.M.	Rated G.P.M.	=	"Desired" G.P.M.
	Rated R.P.M.	=	"Desired" R.P.M.
DETERMINING THE REQUIRED H.P.	GPM x PSI	=	Electric Brake
	1460	=	H. P. Required
DETERMINING MOTOR PULLEY SIZE	Motor Pulley O.D.	=	Pump Pulley O.D.
	Pump R.P.M.	=	Motor R.P.M.

See complete Drive Packages [Incls: Pulleys, Belts, Hubs, Key] Tech Bulletin 003.
Refer to pump **Service Manual** for repair procedure, additional technical information and **pump warranty**.

ITEM	PART NUMBER				DESCRIPTION	QTY
	30 MATL	31 MATL	34 MATL	35 MATL		
2	30057 STL	30057 STL	30057 STL	30057 STL	Key (M6x6x25)	1
5	92519 STZP	92519 STZP	92519 STZP	92519 STZP	Screw, HHC Sems (M6x16)	8
	125824 STCP R	125824 STCP R	125824 STCP R	125824 STCP R	Screw, HHC Sems (M6x16)	8
8	43745 AL	43745 AL	43745 AL	43745 AL	Cover, Bearing	1
10	43343 NBR	43343 NBR	43343 NBR	43343 NBR	O-Ring, Bearing Case - 70D	2
11	43222 NBR	43222 NBR	43222 NBR	43222 NBR	Seal, Oil, Crankshaft - 70D	1
15	14480 STL	14480 STL	14480 STL	14480 STL	Bearing, Ball	2
20	45883 HS	45883 HS	45883 HS	48737 TNM	Rod, Connecting, Assy	3
25	44923 FCM	45911 FCM	44945 FCM	44270 FCM	Crankshaft, Single End	1
30	44944 AL	44944 AL	44944 AL	44944 AL	Cover, Blind Shaft	1
31	828710 —	828710 —	828710 —	828710 —	Protector, Oil Cap w/Foam Gasket	1
32	43211 ABS	43211 ABS	43211 ABS	43211 ABS	Cap, Oil Filler	1
	44666 RTP	—	44666 RTP	44666 RTP	Cap, Oil Filler, Domed - Gearbox Models	1
33	14177 NBR	14177 NBR	14177 NBR	14177 NBR	O-Ring, Filler Cap - 70D	1
37	92241 —	92241 —	92241 —	92241 —	Gauge, Oil, Bubble w/Gasket - 80D	1
38	44428 NBR	44428 NBR	44428 NBR	44428 NBR	Gasket, Flat, Oil Gauge - 80D	1
40	92520 STZP	92520 STZP	92520 STZP	92520 STZP	Screw, HHC Sems (M6x20)	4
	126541 STCP R	126541 STCP R	126541 STCP R	126541 STCP R	Screw, HHC Sems (M6x20)	4
48	25625 STCP	25625 STCP	25625 STCP	25625 STCP	Plug, Drain (1/4"x19BSP)	1
49	23170 NBR	23170 NBR	23170 NBR	23170 NBR	O-Ring, Drain Plug - 70D	1
50	48777 AL	48777 AL	48777 AL	48777 AL	Cover, Rear [10/01]	1
51	48773 NBR	48773 NBR	48773 NBR	48773 NBR	O-Ring, Crankcase Cover [10/01]	1
53	48774 AL	48774 AL	48774 AL	48774 AL	Crankcase [10/01]	1
56	43355 POP	43355 POP	43355 POP	43355 POP	Pan, Oil	1
64	43351 CM	43351 CM	43351 CM	43351 CM	Pin, Crosshead	3
65	45908 ZZCP	45908 ZZCP	45908 ZZCP	45908 ZZCP	Rod, Plunger, Short	3
70	43228 NBR	43228 NBR	43228 NBR	43228 NBR	Seal, Oil, Crankcase	3
75	43328 S	43328 S	43328 S	43328 S	Slinger, Barrier	3
88	45697 S	45697 S	45697 S	45697 S	Washer, Keyhole (M18)	3
90	43367 CC	43367 CC	43367 CC	43367 CC	Plunger (M20x72)	3
95	89648 STZP	89648 STZP	89648 STZP	89648 STZP	Stud, Plunger Retainer (M6x64.5)	3
	126558 STCP R	126558 STCP R	126558 STCP R	126558 STCP R	Stud, Plunger Retainer (M6x64.5)	3
96	43235 PTFE	43235 PTFE	43235 PTFE	43235 PTFE	Back-up-Ring, Plunger Retainer	3
97	17399 NBR	17399 NBR	17399 NBR	17399 NBR	O-Ring, Plunger Retainer - 80D	3
	14160 FPM	14160 FPM	14160 FPM	14160 FPM	O-Ring, Plunger Retainer - 70D	3
98	45891 CU	45891 CU	45891 CU	45891 CU	Gasket	3
99	46504 S	46504 S	46504 S	46504 S	Retainer, Plunger (M6)	3
100	45688 PVDF	45688 PVDF	45688 PVDF	45688 PVDF	Retainer, Seal, 2-Pc [04/06]	3
101	43302 —	43302 —	43302 —	43302 —	Wick, Long Tab	3
106	43305 NBR	43305 NBR	43305 NBR	43305 NBR	Seal, LPS w/S-Spg	3
	45153 FPM	45153 FPM	45153 FPM	45153 FPM	Seal, LPS w/SS-Spg	3
120	45679 BB	45679 BB	45679 BB	45679 BB	Case, Seal	3
121	14200 NBR	14200 NBR	14200 NBR	14200 NBR	O-Ring, Seal Case - 70D	3
	11719 FPM	11719 FPM	11719 FPM	11719 FPM	O-Ring, Seal Case	3
125	43307 SNG	43307 SNG	43307 SNG	43307 SNG	Seal, HPS w/S	3
	44936 FPM	44936 FPM	44936 FPM	44936 FPM	Seal, HPS w/SS	3
	46667 HT	46667 HT	46667 HT	46667 HT	Seal, HPS 2-Pc w/S-Support, Hi-Temp	3
139	22179 BBCP	22179 BBCP	22179 BBCP	22179 BBCP	Plug, Inlet (1/2" NPT)	1
162	48361 D	48361 D	48361 D	48361 D	Back-up-Ring, Seat	6
163	43358 NBR	43358 NBR	43358 NBR	43358 NBR	O-Ring, Seat - 70D	6
	44938 FPM	44938 FPM	44938 FPM	44938 FPM	O-Ring, Seat - 70D	6
164	43725 S	43725 S	43725 S	43725 S	Seat	6
166	43723 S	43723 S	43723 S	43723 S	Valve	6
167	43750 S	43750 S	43750 S	43750 S	Spring	6
168	44565 PVDF	44565 PVDF	44565 PVDF	44565 PVDF	Retainer, Spring	6
172	17615 NBR	17615 NBR	17615 NBR	17615 NBR	O-Ring, Valve Plug - 75D	6
	15855 FPM	15855 FPM	15855 FPM	15855 FPM	O-Ring, Valve Plug - 70D	6
174	46756 BB	46756 BB	46756 BB	46756 BB	Plug, Valve	6
185	45062 BB	45062 BB	45062 BB	45062 BB	Head, Manifold	1
188	124396 STZP	124396 STZP	124396 STZP	124396 STZP	Screw, HSH Sems (M10x35)	2
	126520 STCP R	126520 STCP R	126520 STCP R	126520 STCP R	Screw, HSH Sems (M10x35)	2
196	43633 BB	43633 BB	43633 BB	43633 BB	Plug, Discharge, (3/8" NPT)	1
255	—	30243 STZP	—	—	Mount Kit, Direct (Belt Drive Only)	1
260	—	30611 STZP	—	—	Rail Mounting, Angle - B	1
265	—	30659 —	—	—	Kit, Complete Mounting (Incls: 30611, 30633, 118672)	1
270	—	30633 STL	—	—	Pulley & Key Assy (Incls: 30058, 30057)	1
275	—	30944 STL	—	—	Hub & Key Assy (Incls: 30945, 300057)	1
277	34131 AL	34131 AL	34131 AL	34131 AL	Housing, Bell (184TC)	1
278	8230 AL	8230 AL	8230 AL	8230 AL	Flexible Coupling & Key (M20 to 1-1/8")	1
283	34334	34334	34334	34334	Kit, Oil Drain	1
298	34962 STZP	34962 STZP	34962 STZP	34962 STZP	Clutch Assy, Single Groove, 20mm, 12VDC	1
	34963 STZP	34963 STZP	34963 STZP	34963 STZP	Clutch Assy, Dual Groove, 20mm, 12VDC	1

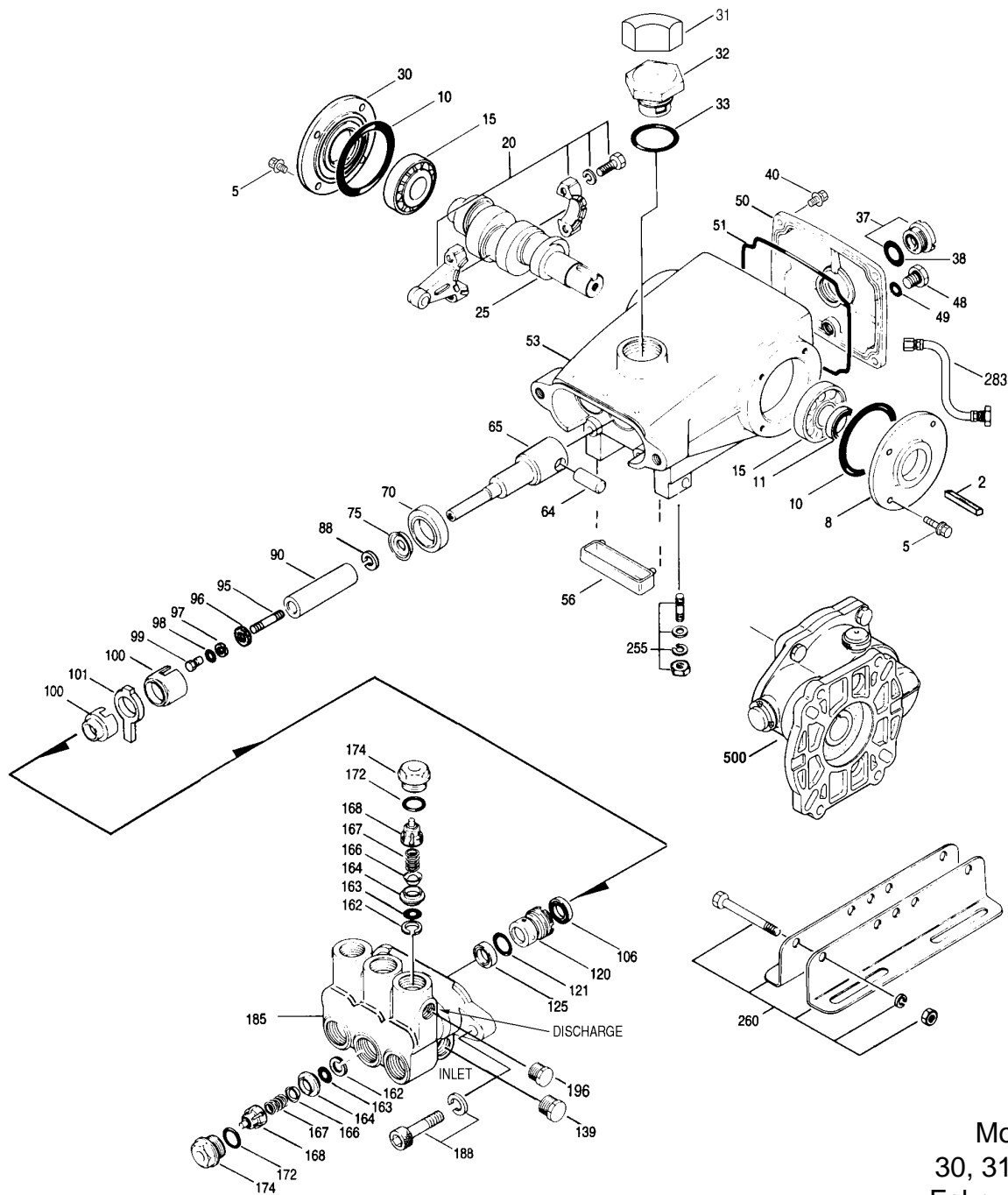

Models
30, 31, 34, 35
February 2007

	30 MATL	31 MATL	34 MATL	35 MATL		
299	812208 FBB	812208 FBB	812208 FBB	812208 FBB	Head, Complete	1
300	30623 NBR	30623 NBR	30623 NBR	30623 NBR	Kit, Seal (Incls: 97,101,106,121,125)	1
	34155 FPM	34155 FPM	34155 FPM	34155 FPM	Kit, Seal (Incls: 97,101,106,121,125)	1
	33623 HT	33623 HT	33623 HT	33623 HT	Kit, Seal (Incls: 97,101,106,121,125)	1
310	30821 NBR	30821 NBR	30821 NBR	30821 NBR	Kit, Valve (Incls: 162,163,164,166,167,168,172)	2
	31821 FPM	31821 FPM	31821 FPM	31821 FPM	Kit, Valve (Incls: 162,163,164,166,167,168,172)	2
350	30696 STZP	30696 STZP	30696 STZP	30696 STZP	Plier, Reverse	1
351	33004 STZP	33004 STZP	33004 STZP	33004 STZP	Seal Case Socket, 1/2" Drive	1
500	—	—	8061 —	8061 —	Gearbox (See Individual Data Sheet)	1
—	6575 —	6575 —	6575 —	6575 —	Plunger Pump Service DVD	1
—	6107 —	6107 —	6107 —	6107 —	Oil, Bottle (21 oz.) ISO 68 Multi-viscosity Hydraulic (Fill to specified crankcase capacity prior to start-up)	1

Bold print part numbers are unique to a particular pump model. Italics are optional items. R Components comply with RoHS Directive.

[] Date of latest production change. See Tech Bulletins 003, 024, 036, 074, 077, 078, 083 and 090 for additional information.

See 8051-8078 Gearbox Gas Engine Drive and 8023ES-8029ES BD Electric Motor Drive data sheets for additional information.

MATERIAL CODES (Not Part of Part Number): ABS=ABS Plastic AL=Aluminum BB=Brass BCCP=Brass/Chrome Plated CC=Ceramic CM=Chrome-Moly CU=Copper D=Acetal FBB=Forged Brass FCM=Forged Chrome-moly FPM=Fluorocarbon HS=High Strength HT=High Temp (EPDM Alternative) NBR=Medium Nitrile (Buna-N)

POP=Polypropylene PTFE=Pure Polytetrafluoroethylene PVDF=Polyvinylidene Fluoride RTP=Reinforced Composite

S=304SS SNG=Special Blend (Buna) STL=Steel STCP=Steel/Chrome Plated STZP=Steel/Zinc Plated ZZ/CP=Zamak/Chrome Plated

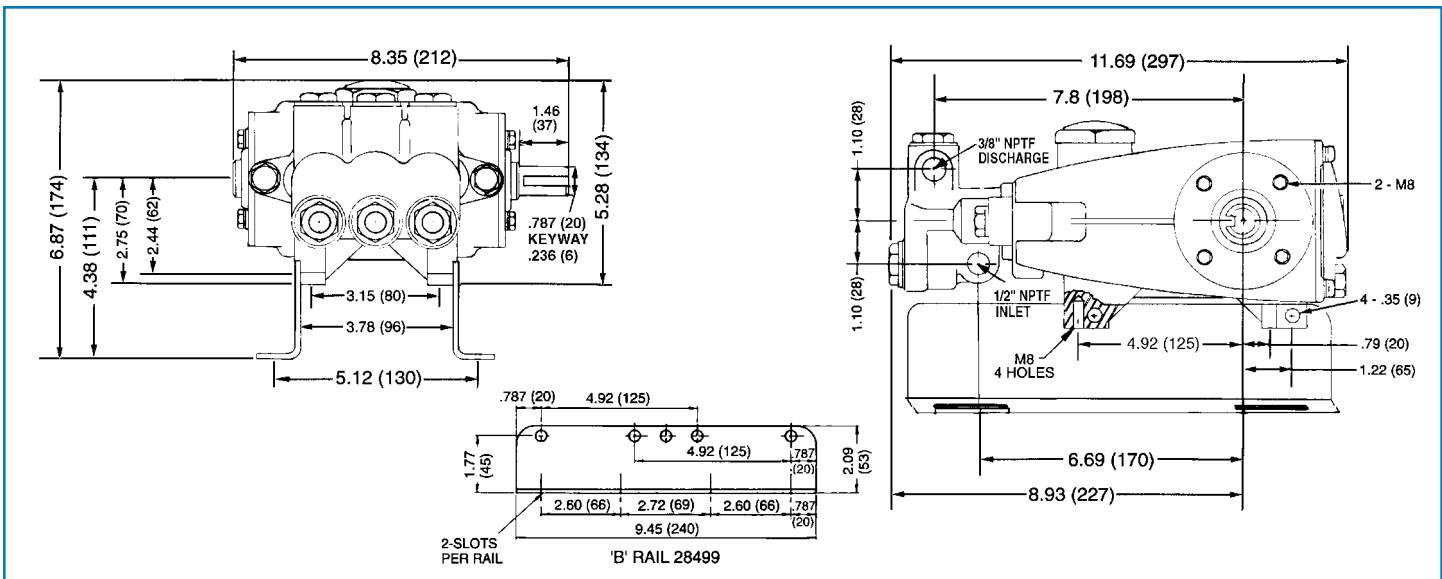

Models 30, 31, 34, 35

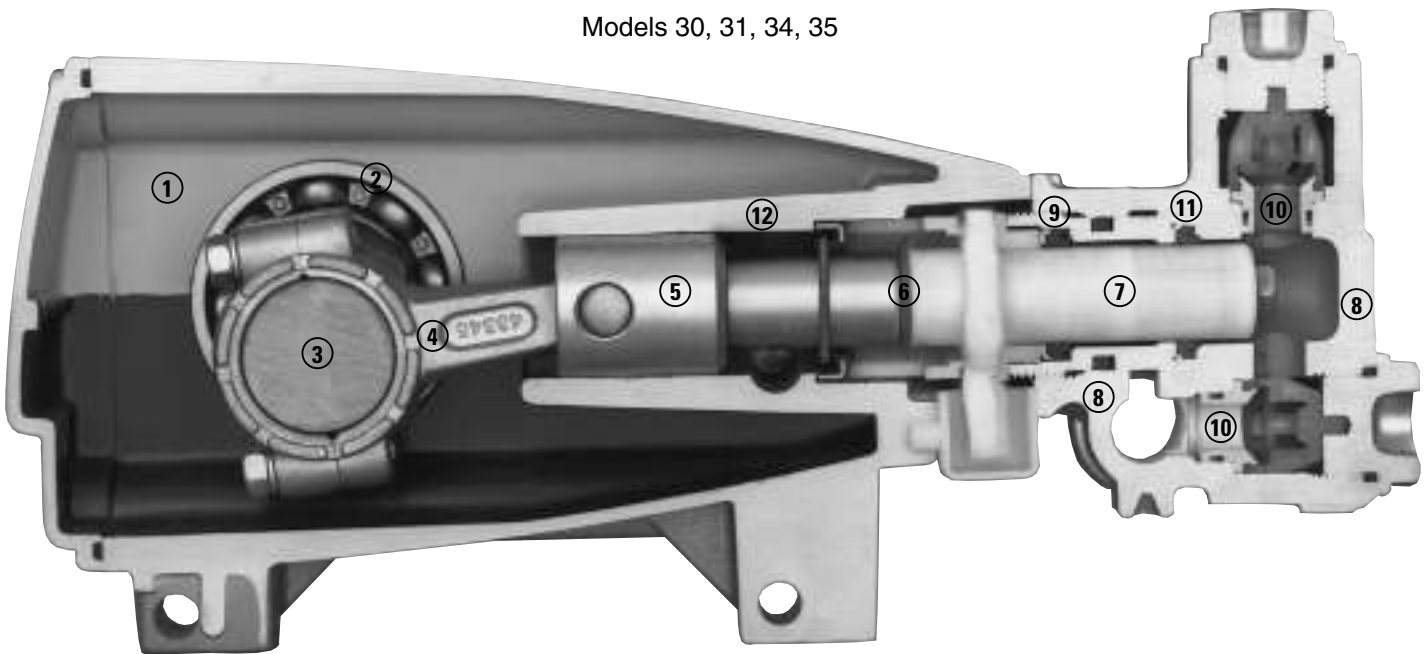

- 1 Die cast aluminum **crankcase** means high strength, light weight, and excellent tolerance control.
- 2 Oversized crankshaft **bearings** provide extended bearing life and pump performance.
- 3 Chrome-moly **crankshaft** provides unmatched strength and surface hardness for long life.
- 4 Matched oversized high strength **connecting rods** noted for superior strength and bearing quality.
- 5 Special high strength **plunger rods** with ZAMAK crossheads for longevity and corrosion resistance.
- 6 The stainless steel **slinger** provides back-up protection for the crankcase seal, keeping pumped liquids out of the crankcase.
- 7 Special concentric, high-density, polished, solid ceramic **plungers** provide a true wear surface and extended seal life.
- 8 **Manifolds** are a high tensile strength forged brass for long term, continuous duty.
- 9 100% **wet seal** design adds to service life by allowing pumped liquids to cool and lubricate on both sides.
- 10 Stainless steel **valves, seats and springs** provide corrosion-resistance, ultimate seating and extended life.
- 11 Specially formulated, CAT PUMP exclusive, **Hi-Pressure Seals** offer unmatched performance and seal life.
- 12 **Crossheads** are 360° supported for uncompromising alignment.

World Headquarters

CAT PUMPS

1681 - 94th Lane N.E. Minneapolis, MN 55449-4324

Phone (763) 780-5440 — FAX (763) 780-2958

e-mail: techsupport@catpumps.com

www.catpumps.com

International Inquiries

FAX (763) 785-4329

e-mail: intlsales@catpumps.com



The Pumps with Nine Lives

CAT PUMPS (U.K.) LTD.

1 Fleet Business Park, Sandy Lane, Church Crookham

FLEET, Hampshire, GU52 8BF, England

Phone Fleet 44 1252-622031 — Fax 44 1252-626655

e-mail: sales@catpumps.co.uk

N.V. CAT PUMPS INTERNATIONAL S.A.

Heiveldekens 6A, B-2550 Kontich, Belgium

Phone 32-3-450.71.50 — Fax 32-3-450.71.51

e-mail: cpi@catpumps.be www.catpumps.be

CAT PUMPS DEUTSCHLAND GmbH

Buchwiese 2, D-65510 Idstein, Germany

Phone 49 6126-9303 0 — Fax 49 6126-9303 33

e-mail: catpumps@t-online.de www.catpumps.de