

DESCRIPTION

Plunger Pumps are designed for a wide variety of moderate pressure washing applications. They are constructed with die-cast bodies and feature a brass head. Internal components include special thick solid ceramic plungers for long life and durability. Precision cast cooling fins are anodized for maximum heat dissipation. Oversized needle bearing on the drive sides and ball bearings on the non-drive side assure proper shaft alignment and maximum life. Valve cages of special designed Ultra-Form impervious to water absorption provide positive seating and extended life. One-piece connecting rods are either a special alloy aluminum or bronze at higher pressures, oversized for strength and load disbursement.



SPECIFICATIONS

MAX GPM	1	MAX LMP.....	3.8
MAX PSI.....	1500	MAX BAR	103
POWER EBHP	1	BORE DIA. MM.....	15
STROKE MM.....	4.83	WEIGHT LBS.....	10
MAX TEMP	140°	OIL CAPACITY.....	8oz
INLET THREAD	1/2" F	DISCHARGE THREAD	3/8" F

DIMENSIONS

XTA

E version + F8
Hollow shaft pump \varnothing 5/8"

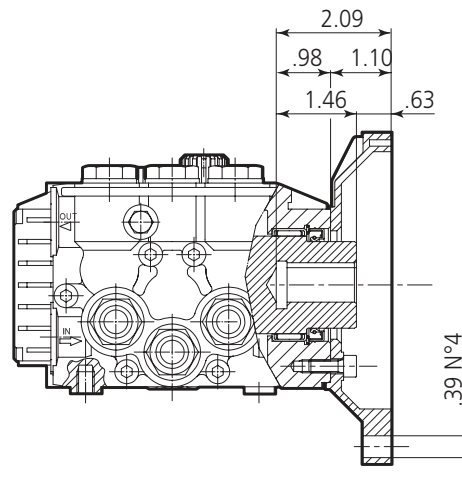
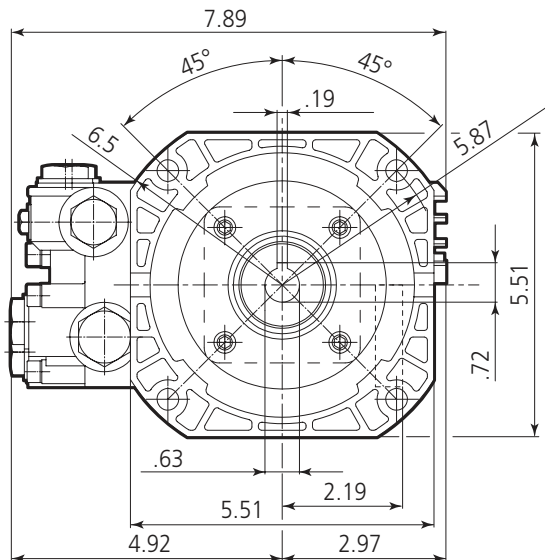

SPECIAL FEATURES

WET END

- **Manifold:**
 - **Forged Brass:** Strength and no porosity equals long life. Higher hydrostatic pressures, safety, performance.
 - **Inlet and Discharge Ports:** Heavy bosses for added strength.
 - **Offset Discharge Ports:** High efficiency, smooth flow.
 - **Bolts:** Six Bolts, 6mm, grade 12.9.
- **Valves:**
 - **Ultra Form Cages:** Durability, strength and long life.
 - **Poppets, Seat and Spring:** 303 and 400 series stainless steel.
 - **Valve Caps:** Machined brass – greater strength.
- **Packing and Plungers:**
 - **High Pressure Packing:** "V" style (D-1) Buna-N (cotton duct weave base) strong and tightens under load.
 - **Low Pressure Seals:** "U" cup double lip Buna-N. Good positive seal.
 - **Support Guides:** Machined brass one-piece construction to assure proper plunger alignment and to maximize packing and seal life.
 - **Plungers:** Are a special aluminum oxide blend, solid ceramic for long life, strong durability and more resilient.

DRIVE END

- **Bearings:** Oversized for maximum life and load disbursement, two ball bearings on the solid shaft series and a needle bearing on the drive side and ball on the non-drive side for the hollow shaft series. Each bearing is held in position on the crankshaft and crankcase by snap rings. This assures positive alignment and centering of the connecting rods and crankshaft in relation to the crankcase, it also eliminates the crankshaft from floating.
- **Crankcase:** Precision die-cast, large cooling fins and anodized (for maximum heat dissipation).

- **Rear Cover:** Precision die-cast, precision punched gasket sealed and bayonet style sight glass for positive sealing and locking (no threads to loosen).
- **Plunger Rods:** Stainless steel construction for strength (no plating to scrape off). O-ring plunger sealing system.
- **Rod Pins:** Precision ground and hardened steel, oversized for load disbursement.
- **Connection Rods:** One piece special alloy aluminum based and bronze, oversized for maximum strength, load disbursement, and life. Heavy pin area construction, for added load strength.
- **Crankshaft:** Forged one-piece, precision ground and hardened for extremely long life and durability.
- **Oil Seals and O-rings:** All are constructed of Buna-N rubber. The O-rings have stainless steel garter springs to assure constant tension on the sealing surface.
- **Oil Capacity:** Flat cover 8 oz. and extended cover 10 oz.

EXTRA FEATURES

- **Dyno Proven:** All pumps are dyno tested to assure the theoretical design meets the actual design.
- **Valve Design:** Each pump series has a valve design that optimizes its highest efficiency.
- **Hot Water:** High temperature kits are available to 180° F. Refer to breakdown.
- **Wet End Repair:** Very simple no special tools are required.
- **Mounting Bolt Pattern:** Same on the top and bottom of the crankcase for simple drive side change.
- **Design:** Using advanced fluid handling design programs. Overall pump efficiency is increased.