

DESCRIPTION

This plunger pump will pump up to 2 GPM at 2500 PSI. It spins at 3400 RPM in a direct drive system coupled with a gasoline engine. The matching flange provides convenient connection to most 7/8" shaft 1.1 - 5.5 HP engines. The hollow shafted pump includes a built-in pressure control valve, and chemical injection system.

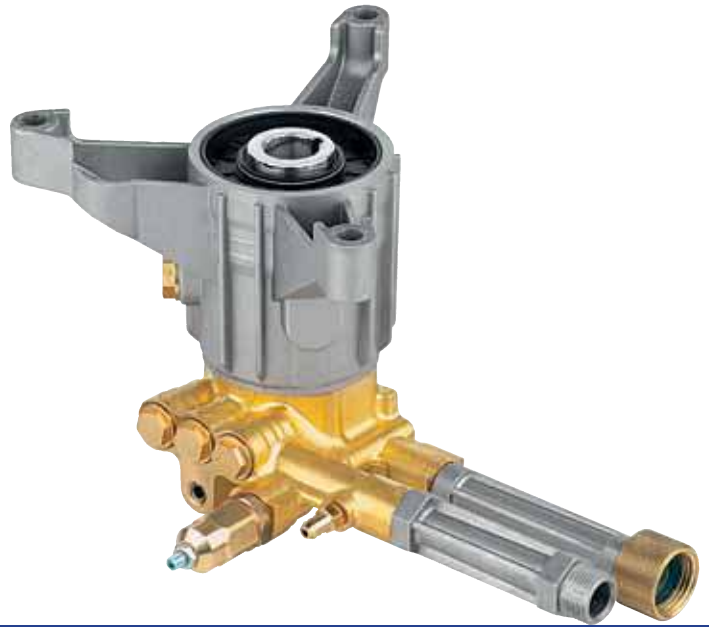

SPECIFICATIONS

MAX GPM 2
 MAX PSI..... 2500
 POWER EBHP 3.4
 STROKE MM..... 8.3
 MAX TEMP 140°
 INLET THREAD 3/4" GH

MAX LMP..... 7.6
 MAX BAR 172
 BORE DIA. MM..... 12
 WEIGHT LBS..... 7.5
 OIL CAPACITY..... 2.2 OZ
 DISCHARGE THREAD 22MM

DIMENSIONS

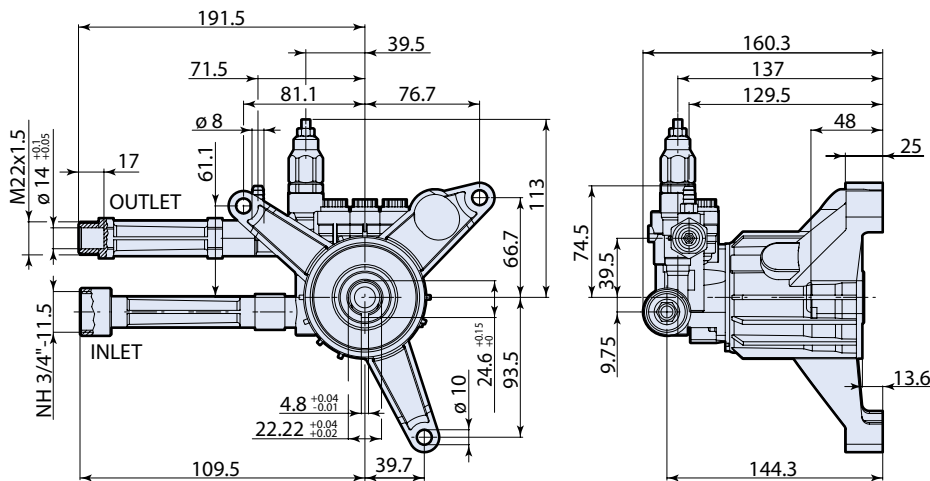

Measurements are - mm

FEATURING

Manifold: Forged brass for long term use.

Bolts: Three 6mm cadmium plated steel.

Plungers: Hardened stainless steel.

Valves: Stainless steel poppet, seat and cage, stainless steel spring.

Seals: Buna-N dual seals.

Bearings: Premium oversized ball and needle bearings.

Crankshaft: Precision die-cast, with cooling fins for maximum heat dissipation. The housing retains the crankshaft bearing, oil seal and rear wobble plate bearing support washer.